

Imperial Conveyor & Engineering

(562) 634-5410

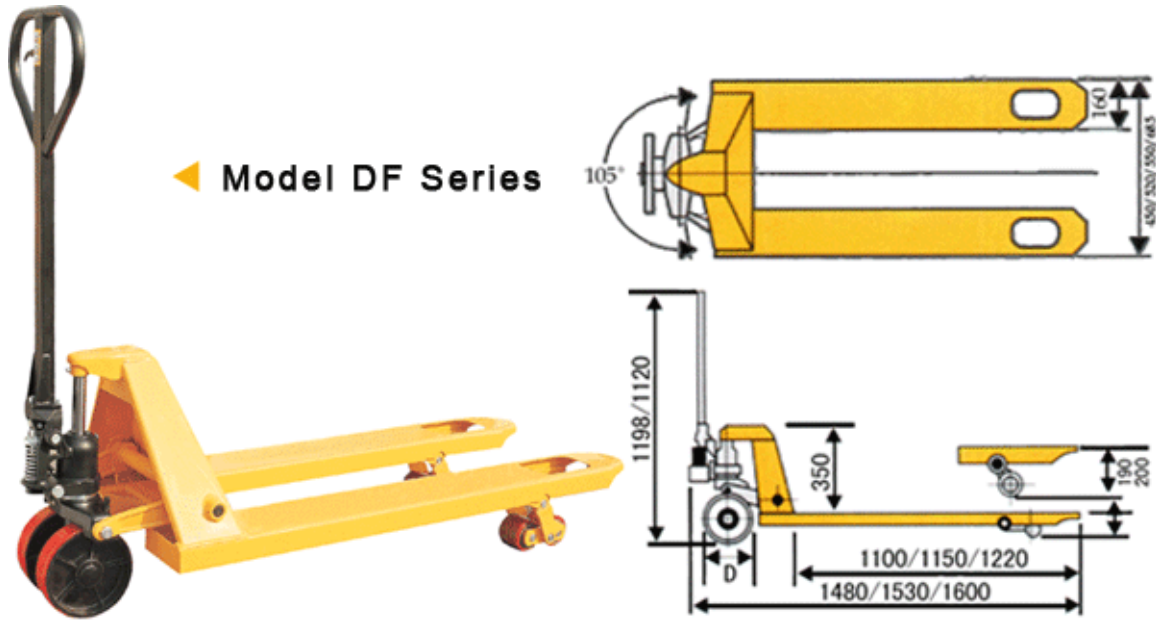

Model		DF20			
Capacity	lbs	4400			
Max. fork height	in	7-7/8	7-1/2	6-11/16	6-5/16
Min. fork height	in	3-3/8	2-15/16	2-3/8	2
Load roller	in	3-1/8" Dia X 3-11/16	2-15/16" Dia X 3-11/16	2-3/8" Dia X 3-11/16	1-15/16" Dia X 3-11/16
Steering wheel	in	7-7/8" Dia X 1-15/16	7-1/16" Dia X 1-15/16		
Size of fork	in	6-5/16" X 2-3/8		6-5/16" X 1-7/16	
Width overall forks	in	18-1/8, 20-1/2, 21-5/8, 27		21-1/4, 27, 33	
Fork length	in	39-3/8, 42, 45-1/4, 48-1/16		45-1/4, 48-1/16	

Imperial Conveyor & Engineering
(562) 634-5410

Model		DF25		DF30	
Capacity	lbs	5500		6600	
Max. fork height	in	7-7/8	7-1/2	7-7/8	7-1/2
Min. fork height	in	3-3/8	2-15/16	3-3/8	2-15/16
Load roller	in	3-1/8" Dia	2-15/16" Dia	3-1/8" Dia	2-15/16" Dia
		X 3-11/16	X 3-11/16	X 3-11/16	X 3-11/16
Steering wheel	in	7-7/8" Dia	7-1/16" Dia	7-7/8" Dia	7-1/16" Dia
		X 1-15/16	X 1-15/16	X 1-15/16	X 1-15/16
Size of fork	in	6-5/16" X 2-3/8			
Width overall forks	in	18-1/8, 20-1/2, 21-5/8, 27			
Fork length	in	39-3/8, 42, 45-1/4, 48-1/16			